

EC-E

TECHNICAL DATA

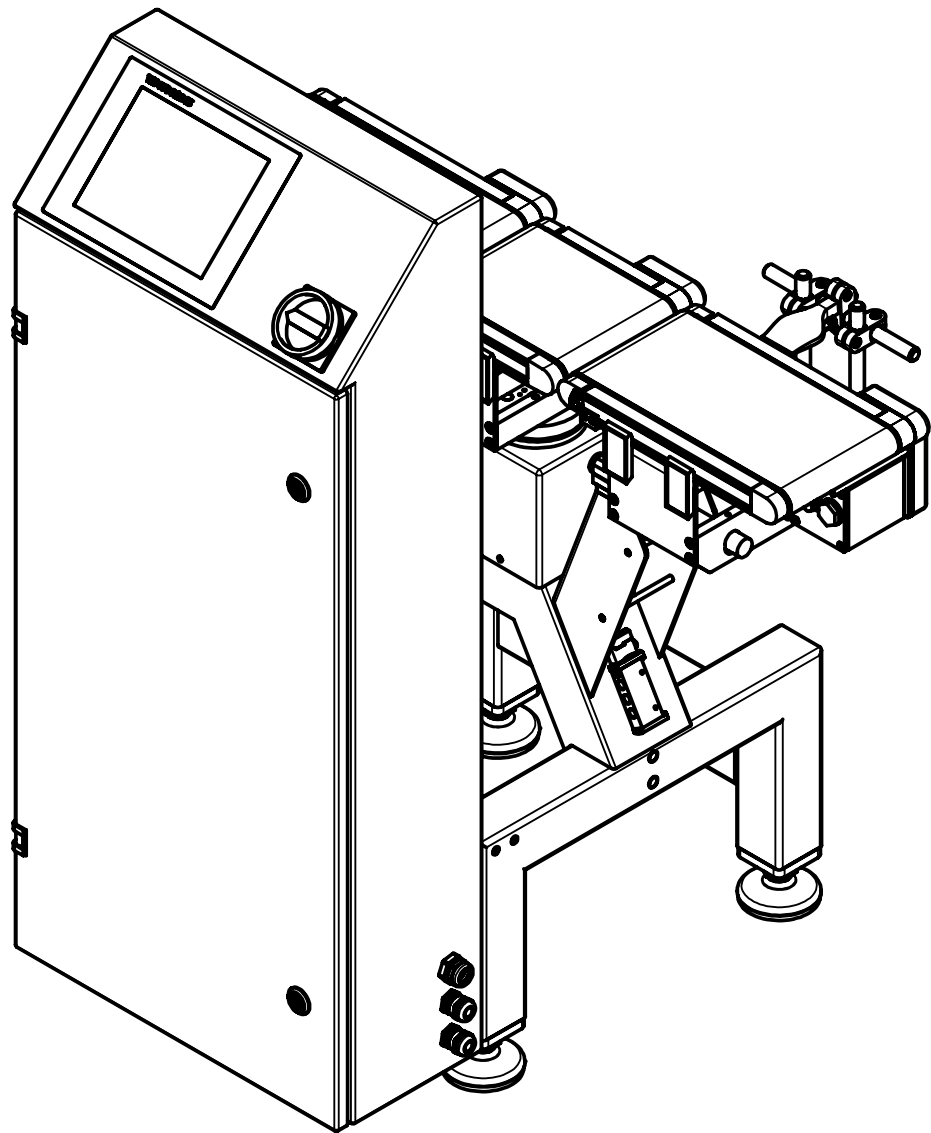

COMPACT DESIGN, BIG PERFORMANCE

EC-E BASIS

Reliability and transparency of production data are the basis of all planning. The **EC-E** checkweigher from WIPOTEC-OCS guarantees 100% data capture in ongoing production.

Capable of 150 weight values per minute, the EC-E is the right choice for you. The intuitive user interface ensures convenient operation via a clearly structured, 8-inch colour touchscreen. The EC-E checkweigher precisely weighs each individual product, records individual values, and ejects incorrect weight packages via the fully

automated sorter. Your data is correctly and completely collected and you have the certainty that only factory compliant products leave your production halls.

The checkweigher's ease of use virtually excludes all incorrect entries. A reliable high-tech machine, especially in the dry foods

sector, with a very good price-performance ratio in the EMFR entry segment.



MAIN FEATURES

- ✔ WIPOTEC Weighing Technology EMFR Weigh Cells
- ✔ Stainless steel frame
- ✔ Stainless steel cabinet with integrated control system
- ✔ Three NT30 belts (infeed, weighing and outfeed conveyors); Lightweight construction
- ✔ Maintenance-free servo drives
- ✔ One sorter attachment (air blast)
- ✔ User friendly interface via 8" colour TFT touchscreen display
- ✔ Memory for 50 different product parameters (option to expand to 200)
- ✔ Line synchronisation with potential-free switching contacts/binary signals
- ✔ Extensive statistical functions/histograms

YOUR BENEFITS

- ✔ High throughput rate of up to 150 pcs/min
- ✔ Precise and reliable weighing results to increase plant efficiency
- ✔ Very good price-performance ratio
- ✔ Requirements-based modularity for the greatest flexibility

TECHNICAL DATA

EC-E BASIS

BASE DATA

Material of machine	Frame stainless steel V2A/AISI 304
Machine weight (standard application)	100 kg
Shipping weight (standard application)	140 kg
Protection class	IP65
Temperature range	+5 °C to +40 °C
Display and operation	8" colour TFT display with touchscreen
Available dialog languages	Bosnian, Chinese, Croatian, Danish, Dutch, English, Finnish, French, German, Greek, Italian, Japanese, Latvian, Lithuanian, Polish, Portuguese, Russian, Swedish (other languages on request)
Interfaces ¹⁾	Optionally: Ethernet, RS232, RS422, RS485
Max. output ²⁾	150 pcs/min
Digital I/O	8xI + 12xO
Product parameter storage	50 PPS (optionally 100 / 200 PPS)
Drive	Servo-Technology
Noise level ²⁾	A-weighted emission sound pressure level under 70dB(A)
Rated voltage	L1/N/PE; 100-240 VAC
Rated frequency	50/60 Hz
Connect load (power capacity)	Approx. 0.8 kVA
Compressed air supply (option)	8 bar approx. 10NI/min quality class (according to ISO 8573-1) [5:3:3]
Possible maximum numbers of connected motors	3 motors (optionally 1 extendible)
EU-type examination certificate	DE-18-MI006-PTB001 (MID)

WEIGHING DETAILS

	Weigh Cell (Type)	GWR (Gross weighing range)	Dead load max.	e (min. cali- bration value)	d (Displayed value)	Standard deviation ²⁾ (1s)	n (Scale division)
EC-E-1	EC 4000-E	1,500 g	8,500 g	≥ 0.5 g	≥ 0.2 g	from 150 mg	3,000
EC-E-2	EC 4000-E	3,000 g	8,500 g	≥ 1.0 g	≥ 0.5 g	from 150 mg	3,000
EC-E-3	EC 4000-E	6,000 g	8,500 g	≥ 2.0 g	≥ 1.0 g	from 150 mg	3,000

1) Optionally, surcharge

2) Depending on product shape, product behavior, transport speed and environmental condition

CONVEYOR DIMENSIONS

		Dimensions weighing conveyor		
length \ width	150 mm	200 mm	300 mm ¹⁾	
200 mm	X	-	-	
300 mm	X	X	-	
400 mm	X	X	X	
500 mm ¹⁾	X	X	X	

		Dimensions infeed / outfeed conveyor		
length \ width	150 mm	200 mm	300 mm ¹⁾	
300 mm	X	X	-	
400 mm	X	X	X	
500 mm	X	X	X	
600 mm	X	X	X	

1) Optionally, surcharge

MACHINE DIMENSIONS

EC-E BASIS

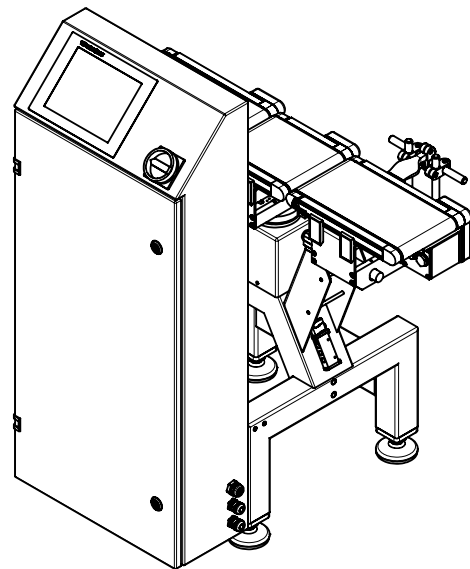
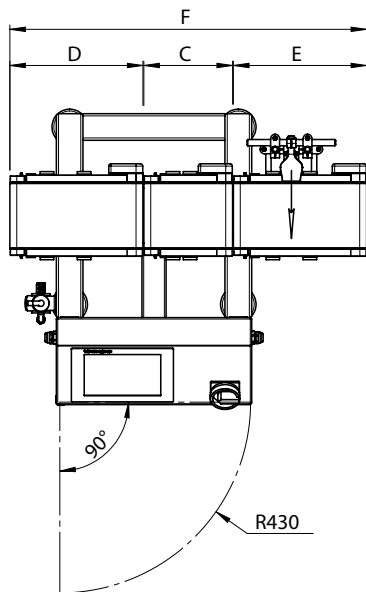
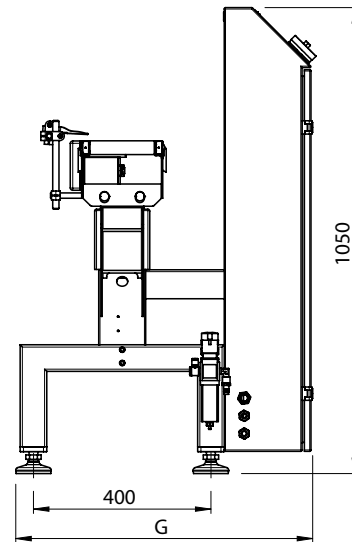
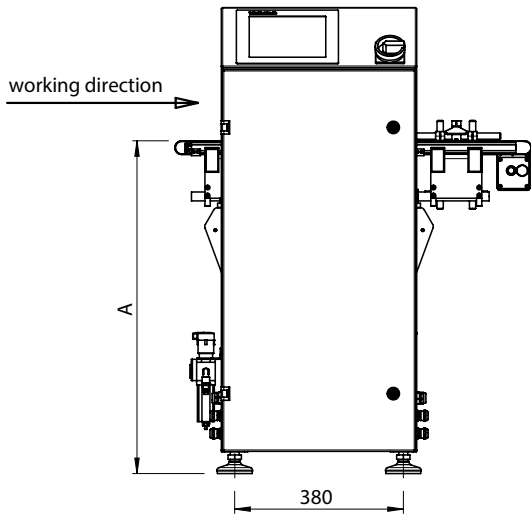

A = Working height¹⁾	650-800 ²⁾ / 750-900 / 850-1,000 / 950-1,100 ²⁾ mm
B = Conveyor width	150 / 200 / 300 ²⁾ mm
Conveyor technology NT 30	Roller diameter 30 mm
C = Weighing conveyor length	200 / 300 / 400 / 500 ²⁾ mm
D = Infeed conveyor length	300 / 400 / 500 / 600 mm
E = Outfeed conveyor length	300 / 400 / 500 / 600 mm
F = Total length	D + C + E + 10 mm
G = Total width	670 mm depending on machine configuration

1) Working height must be specified when ordering
2) Optionally, surcharge

These specifications are reference values of the standard machine excluding application- or weighing-specific add-on parts.
All entries in mm | Drawing shows design example

